

# General Radio EXPERIMENTER

VOLUME XXVII No. 9

FEBRUARY, 1953

Copyright, 1953, General Radio Company, Cambridge, Mass., U. S. A.



ELECTRICAL MEASUREMENTS AND THEIR INDUSTRIAL APPLICATIONS

## TYPE 1212-A UNIT NULL DETECTOR

*Also*  
**IN THIS ISSUE**

	<i>Page</i>
TYPE 1212-P1 HIGH-PASS FILTER.....	5
TYPE 1951-A FILTER.....	6
THE MEASUREMENT OF CABLE CHARACTERISTICS.....	7
"UNIVERSAL" COAXIAL ADAPTORS.....	8

● **THE ADDITION** of the TYPE 1212-A Unit Null Detector to the unit instruments already announced<sup>1</sup> marks another step towards the completion of a comprehensive set of building-block instruments.

In recognition of the increasing complexity of measuring equipment, the unit instruments have been designed, individually, to perform fundamental tasks simply and well. Taken in combination, they have also been planned to work cooperatively in systems of greater complexity. Sound electrical circuitry, combined with mechanical design that incorporates only the essential features, makes these instruments the equal in quality of any made by General Radio. They are small in size, light,

and rugged. The design of the Unit Null Detector is particularly noteworthy. The plug at the left connects to the Type 1203-A or Type 1204-B Unit Power Supply. At the option of the user, the power supply may be plugged in for easy assembly and disassembly or permanently bolted to the instrument to form a complete rigid assembly.

<sup>1</sup>See references at end of article.

Figure 1. Panel view of the Unit Null Detector. The plug at the left connects to the Type 1203-A or Type 1204-B Unit Power Supply. At the option of the user, the power supply may be plugged in for easy assembly and disassembly or permanently bolted to the instrument to form a complete rigid assembly.

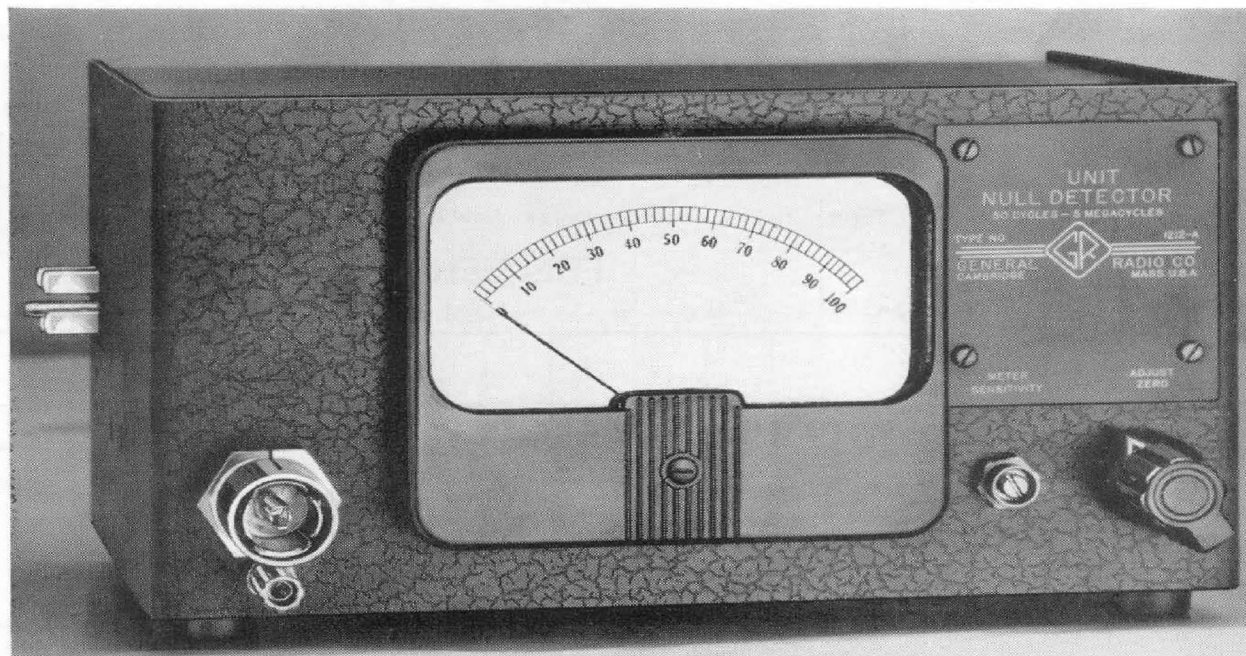

in weight, and basically "miniaturized," since the two standard cabinets have been found, in general, to be about as small, for the heat developed within them, as good engineering practice will allow.

In the unit instruments the user therefore receives, at modest cost, laboratory quality for accuracy, dependability, and sturdiness; miniaturized packaging for maximum convenience and minimum use of bench space; straightforward, simple design for easy utility; and versatility that permits wide application in either simple or complex measuring systems.

The TYPE 1212-A Unit Null Detector, intended primarily as a balance indicator for a-c bridges, is useful generally as a sensitive, wide-frequency-range voltage indicator. Its frequency characteristic is flat within about 1 db from 50 c to 500 kc, and it is satisfactory as an indicator at frequencies between about 20 c and 5 Mc. Its over-all gain is about 70 db, and it provides a deflection of one per cent of full scale for an input signal of less than 40  $\mu$ v. An approximately logarithmic relationship between input voltage and meter reading is displayed on an arbitrary 0-100 scale, and the combination of high sensitivity at low input levels with a full-scale deflection of about 100 volts yields an on-scale range of approximately 120 db. Typical frequency-response and voltage-response curves are shown in Figures 2 and 3.

For a bridge detector, there are two important advantages of an instrument having these characteristics. The wide frequency range makes possible its use not only with such audio-frequency bridges as the TYPE 716-C Capacitance Bridge, TYPE 667-A Inductance Bridge, and TYPE 561-D Vacuum-Tube Bridge but also with the medium-frequency TYPE 916-AL Radio-Frequency Bridge and, for the lower part of their frequency ranges, with the TYPE 916-A Radio-Frequency Bridge and the TYPE 821-A Twin-T Impedance-Measuring Circuit. The quasi-logarithmic input-output relationship prevents overload caused by large unbalances from masking the approach to balance, and increases the sensitivity automatically as the balance is approached, with consequent maximum precision at the time it is wanted.

These advantages are offset, to some extent, by the noise level resulting from the wide frequency range, which limits the maximum sensitivity that can be usefully supplied, but this limited sensitivity in turn can be offset by an increase in generator voltage to maintain adequate over-all system sensitivity. In fact, it is desirable to obtain the necessary over-all sensitivity by increasing the generator voltage to as high a level as the measuring equipment or the device to be measured will allow, so that any extraneous voltages entering the measuring system will cause minimum disturbance, and the sensitivity of the

Figure 2. Frequency response characteristic of the Unit Null Detector.

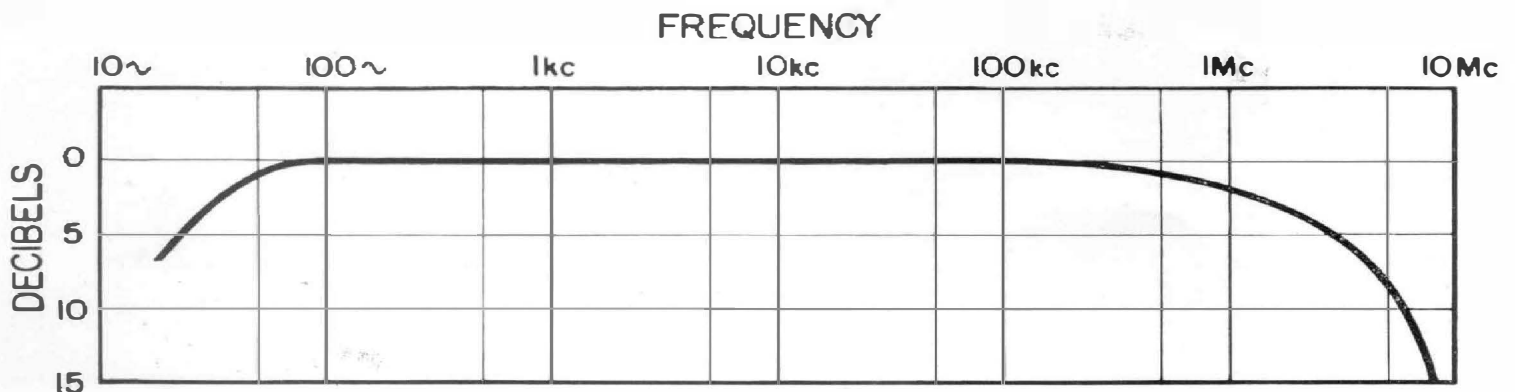



TYPE 1212-A Unit Null Detector under these conditions will normally yield precision of balance for all General Radio bridges well within the bridge accuracy ratings. However, when extreme precision is desired, for instance in determining very small differences in capacitance or dissipation factor with the TYPE 716-C Capacitance Bridge, the use of head telephones will provide approximately 20 db more sensitivity than the meter. Terminals for head telephones are provided at the rear of the instrument.

Even when satisfactorily high levels of input voltage are used, however, extraneous signals and noise can be bothersome with a detector of 40  $\mu\text{v}$  sensitivity and 5 Mc band width, and it is often desirable to use a filter tuned to the generator frequency to obtain maximum precision. Two filters, described in accompanying articles, are available as accessories to remedy commonly encountered difficulties.

The first of these, the TYPE 1212-P1 High-Pass Filter, is a simple R-C filter designed to reduce the gain of the TYPE

1212-A Unit Null Detector by about 50 db at 60 cycles. With this filter, measurements can be made at any frequency above about 10 kc without difficulties arising from pickup of power-line frequencies, even in relatively open measuring assemblies. A plot of attenuation as a function of frequency for this filter is shown in the article describing it.

The second of these, the TYPE 1951-A Filter, is intended to provide, at the common 400-cycle and 1000-cycle audio test frequencies, rejection both of extraneous pickup and of harmonics present in the generator voltage or developed in non-linear elements in the bridge itself. Taken in combination, the TYPE 1214-A Unit Oscillator, which provides substantial power output at 400 cycles and 1000 cycles, the TYPE 1951-A Filter, and the TYPE 1212-A Unit Null Detector form an excellent generator-detector system for all General Radio audio-frequency bridges.

An interesting application of this sort, in illustration, is found with the TYPE 667-A Inductance Bridge. The relatively

Figure 3. Voltage response curve for the Unit Null Detector.

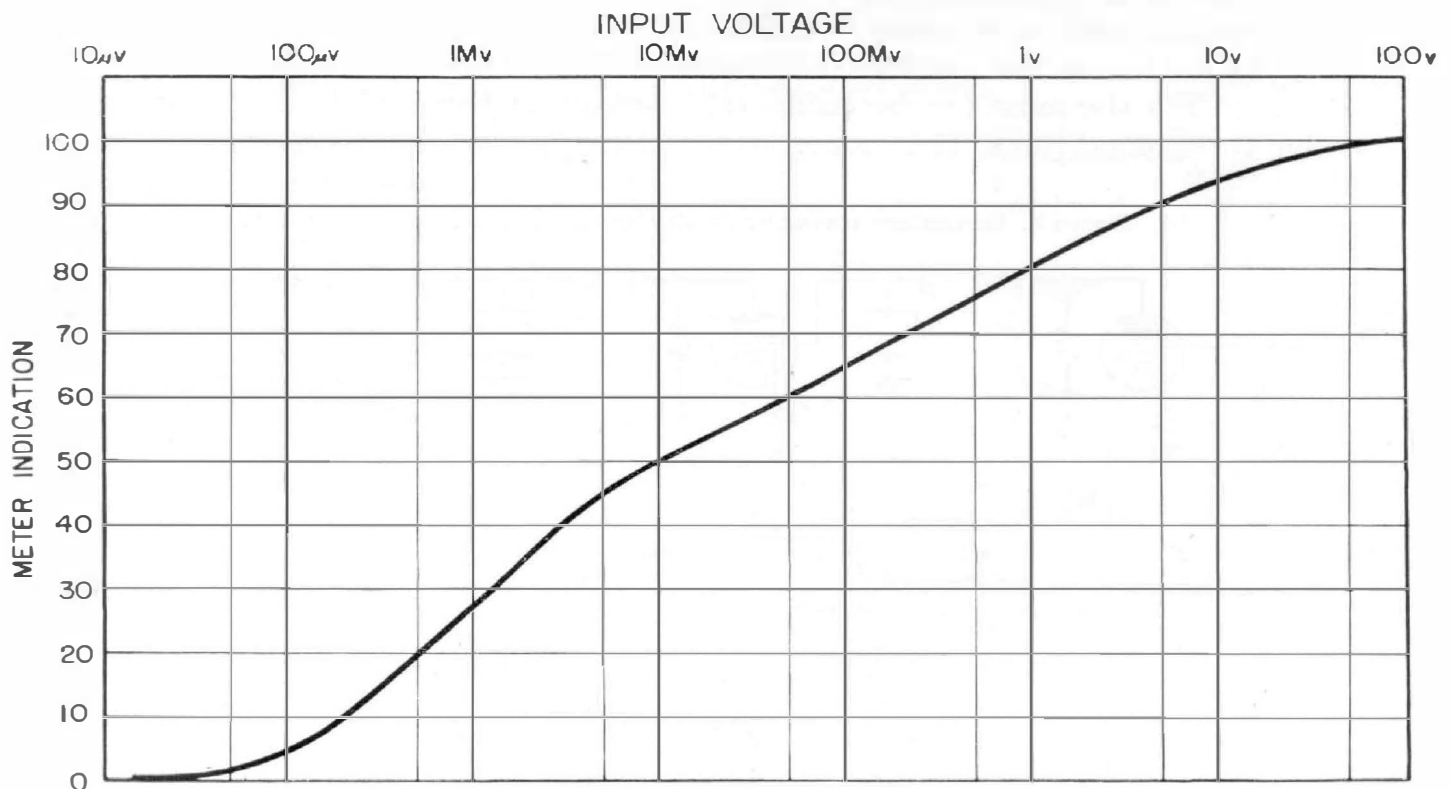

low impedance of this bridge often requires particularly high sensitivity in the detector to assure adequate precision of balance. The TYPE 1951-A Filter, which is provided with a "tap-down" arrangement to match different impedances, actually provides voltage gains of the order of 20 to 30 db from resonant rise at these low impedance levels. Even in this exacting use the combination of the TYPE 1951-A Filter and the TYPE 1212-A Unit Null Detector therefore makes a detector of entirely satisfactory sensitivity.

Another special application occurs when the combination of the TYPE 1214-A, TYPE 1951-A, and TYPE 1212-A is used with the TYPE 561-D Vacuum-Tube Bridge. Two problems arise with this system. The first comes about because the generator voltage is limited to a level that will not cause shift in measured tube coefficients caused by too large excursions over the non-linear tube characteristic curves, with consequent limitation of over-all sensitivity. The second comes about from noise generated by the tube being measured. The net effect is a signal-to-noise ratio considerably larger than that encountered with other bridges, and an exaggerated difficulty in realizing the inherent bridge accuracy. For the most precise balances, under these conditions, it is sometimes

desirable to use head telephones so that the extra discrimination of the ear in separating signal from noise can be used to supplement the electrical filtering.

The TYPE 1212-A Unit Null Detector is provided with a meter to make possible bridge balancing over a frequency range far in excess of that to which the ear will respond. For most tube measurements, the meter is entirely satisfactory but, for unusually noisy tubes, it may be desirable to accept the inconvenience of head telephones to obtain extra discrimination, which is useful not only in rejecting noise but in identifying sources of pick-up and distortion.

For frequencies above the audio range, the TYPE 1212-A Unit Null Detector is useful for most laboratory applications either with no filter or with the TYPE 1212-P1 High-Pass Filter when hum pickup is bothersome. For field application, however, particularly when physically large devices are to be measured, tuned-circuit filters are frequently desirable. Simple home-made filters of the type shown in Figure 5 can be easily constructed to fit the particular requirements of the problem at hand.

For the most exacting applications, such as antenna measurements in the broadcast band, high-grade communication-type radio receivers are recom-

Figure 4. Elementary schematic circuit diagram of the Unit Null Detector.

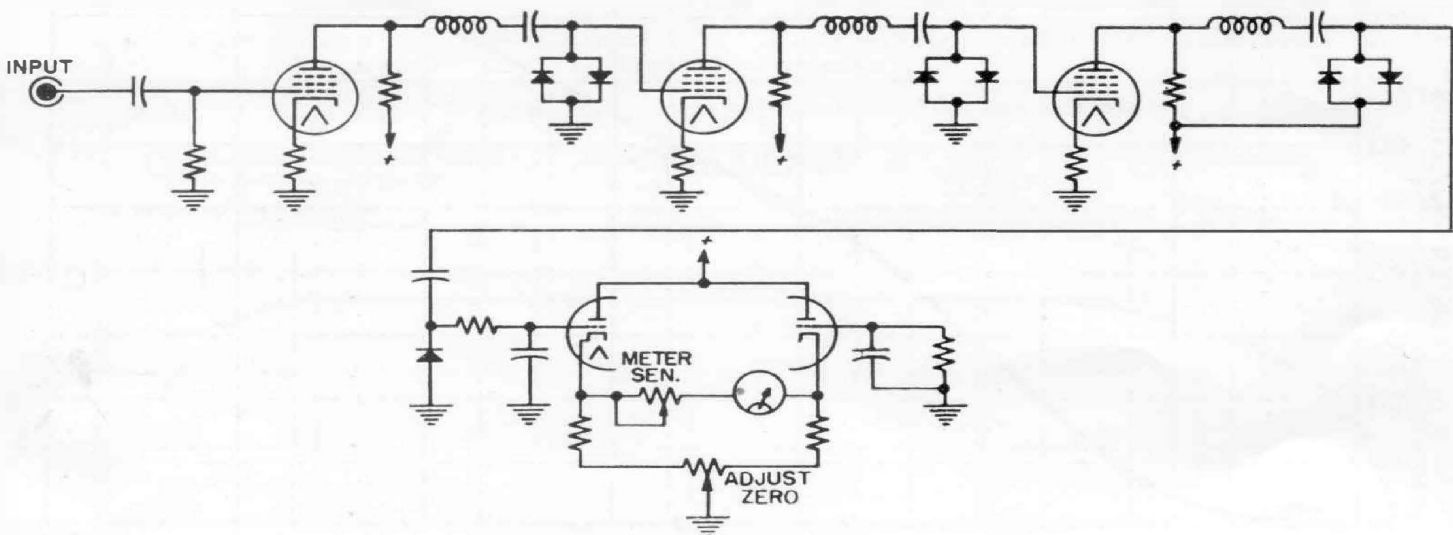



mended to supply the desired selectivity and sensitivity. For less difficult measurement problems, however, the small size and easily read meter of the TYPE 1212-A Unit Null Detector make it a preferable detector.

Figure 4 is an elementary schematic of the TYPE 1212-A. The instrument is seen to be a relatively conventional three-stage broad-band amplifier using series-peaking compensation. The unconventional feature is the use of germanium-diode clippers to obtain the quasi-logarithmic input-output relationship. This method of shaping is important to the proper operation of the instrument since it eliminates the long time-constant that would be necessary to secure proper automatic-volume-control action at low audio frequencies and insures a speed of

<sup>1</sup>Edward Karplus, "V-H-F and U-H-F Unit Oscillators," *General Radio Experimenter*, XXIV, 12, May, 1950.  
 "New Unit Instruments—Power Supplies—Modulator," *General Radio Experimenter*, XXVI, 2, July, 1951.  
 Robert B. Richmond, "The Unit Crystal Oscillator," *General Radio Experimenter*, XXVI, 9, February, 1952.  
 A. G. Bousquet, "A New Unit Oscillator—50 to 250 Mc.," *General Radio Experimenter*, XXVII, 8, January, 1953.

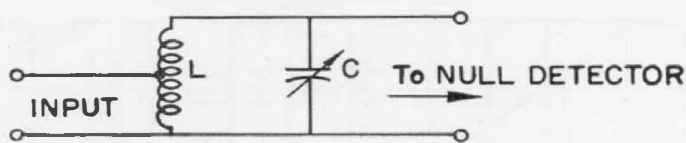

Figure 5. Simple tuned-circuit filter.

response that is limited only by the ballistics of the meter used.<sup>2</sup> These ballistics are so chosen that the instrument is critically damped to make bridge balancing easy and rapid. The balanced meter circuit, combined with regulation of the tube voltages, maintains good stability of meter deflection as the line voltage is varied, and inherent noise in the amplifier is just enough to cause a small meter deflection which can be corrected by the ADJUST ZERO adjustment on the panel. A METER SENSITIVITY control on the panel can be used to set the full-scale meter reading for the voltage range to be displayed.

— ROBERT B. RICHMOND

<sup>2</sup>It should be noted that the clipping destroys the wave-shape of the output signal except at very low input levels. Head telephones should, therefore, be used to study distortion or pick-up only near bridge balance.

### SPECIFICATIONS

**Sensitivity:** Less than 40 microvolts input at 1 kc is required to deflect one per cent of full scale on the meter.

**Voltage Response:** See Figure 3.

**Frequency Response:** See Figure 2.

**Tubes:** The instrument requires three Type

6AK5, one Type 12AX7, and one Type OA2 Tubes which are shipped installed.

**Accessories Available:** TYPES 1212-P1 and 1951-A Filters. TYPE 1203-A Unit Power Supply.

**Dimensions:** (Width) 9½ x (height) 5¾ x (depth) 6 inches, over-all.

**Net Weight:** 5½ pounds.

Type		Code Word	Price
1212-A	Unit Null Detector*	ALACK	\$160.00
1203-A	Unit Power Supply	ALIVE	47.50

\*U. S. Patents Nos. 2,125,816 and 2,548,457.

## TYPE 1212-P1 HIGH-PASS FILTER

The TYPE 1212-P1 10-kc High-Pass Filter is designed primarily for use with the TYPE 1212-A Unit Null Detector to attenuate low-frequency noise and hum. It is a shielded R-C type filter and provides about 50 db attenuation at 60

cycles when used in conjunction with the TYPE 1212-A and fed from a low-impedance source.

It can be used equally well with other equipment, provided the load impedance is of the order of one megohm or higher.

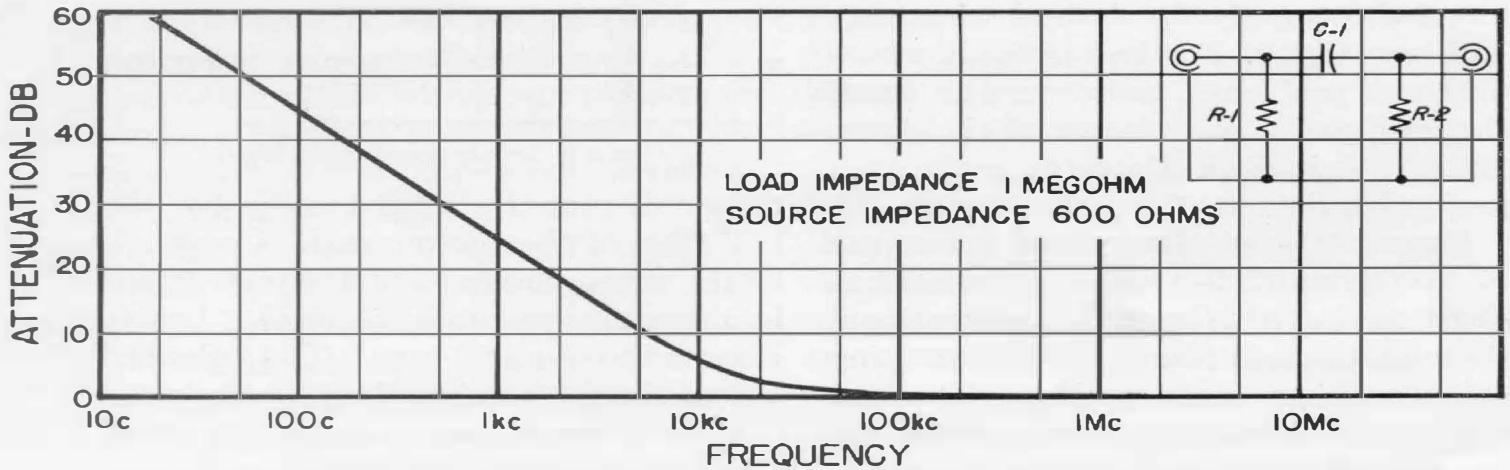

Figure 1. Attenuation characteristics of the Type 1212-P1 High-Pass Filter. The circuit diagram is shown at the upper right.

At lower load impedances or at source impedances of several thousand ohms, the attenuation characteristic will be modified, but useful rejection of low-frequency noise and hum will be found in most cases.

The attenuation characteristic plotted in Figure 1 was measured with a

load impedance of one megohm and a source impedance of 600 ohms. The circuit diagram is shown in the inset.

The filter is housed in a TYPE 874-X Insertion Unit Case, equipped with TYPE 874 Coaxial Connectors at each end. The filter is symmetrical and either end may be used as input or output.

**SPECIFICATIONS**

**Attenuation Characteristic:** See curve (Figure 1).  
**Nominal Load Impedance:** 1 megohm.  
**Input Voltage Limit:** 150 volts maximum.

**Terminals:** TYPE 874 Connector at each end.  
**Dimensions:** 7/8 inch diameter by 4 3/8 inches long.  
**Net Weight:** 3 ounces.

Type	Code Word	Price
1212-P1 High-Pass Filter . . . . .	UNCLE	\$12.00

U. S. Patents Nos. 2,125,816 and 2,548,457.

**TYPE 1951-A FILTER**

The TYPE 1951-A Filter is a parallel-resonant L-C circuit which is tuned to 400 or 1000 cycles per second ±2 per cent. It is designed to operate at the input to high-gain amplifiers such as the General Radio TYPE 1212-A or

Figure 1. Panel view of the Type 1951-A Filter.



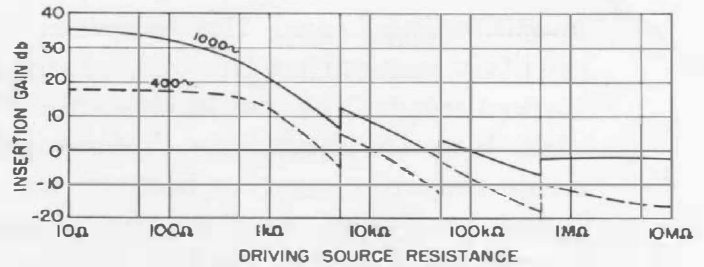
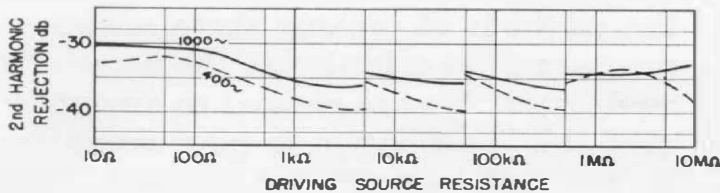

Figure 2. Second harmonic rejection (above) and insertion gain (right) of the Type 1951-A Filter.

TYPE 1231-B. In this position, large amplitude spurious signals such as 60-cycle pickup are attenuated before they have an opportunity to overload the amplifier. This feature is particularly useful when measuring direct capacitance by the 3-terminal method or when using other methods in which portions of the circuit under test are floating above ground and subject to pickup of external voltages. A capacitive divider on the input side allows the filter to be operated at close to optimum conditions regardless of the impedance it sees at its input.

The insertion gain or loss, working into a one megohm load, and the second harmonic rejection are shown in the curves, Figure 2.

The inductor of the TYPE 1951-A

Filter is wound on a molybdenum-permalloy dust-core toroid and enclosed in a permalloy shield. All circuit elements are shielded against electrostatic pickup. These precautions are taken so that the filter may be used at the very low voltage levels encountered at the input to high-gain amplifiers such as the General Radio TYPE 1212-A or TYPE 1231-B. Any pickup that remains can usually be eliminated by properly positioning and orienting the filter.

If a shielded input is desired, the TYPE 274-MB and TYPE 274-ND Double Plugs may be used. The output cord may be terminated in the TYPE 874-Q6 Adaptor for TYPE 874 Connectors, the TYPE 274-MB or TYPE 274-ND for  $\frac{3}{4}$  inch spaced binding posts, or left un-terminated for telephone tip leads.

### SPECIFICATIONS

**Frequency:** 400 cycles and 1000 cycles.

**Maximum Allowable R-M-S Input Voltage:**

Input Impedance Range	1000~	400~
0 — 5KΩ	10 v	4 v
5KΩ — 50KΩ	40 v	16 v
50KΩ — 500KΩ	145 v	58 v
500KΩ — —	200 v	165 v

**Insertion Loss:** See Figure 2.

**Second Harmonic Rejection:** See Figure 2.

**Accessories Supplied:** One TYPE 274-MB Double Plug, one TYPE 274-ND Shielded Plug, and one TYPE 874-Q6 Adaptor\*.

**Dimensions:**  $3\frac{1}{8}$  x  $3\frac{1}{4}$  x  $4\frac{3}{8}$  inches, over-all.

**Net Weight:**  $1\frac{3}{4}$  pounds.

Type	Code Word	Price
1951-A Filter .....	FIBRE	\$65.00

\*U. S. Patents Nos. 2,125,816 and 2,548,457.

## THE MEASUREMENT OF CABLE CHARACTERISTICS

Coaxial cables play an important role in today's electronic world. They are vital elements in television circuits, radar, blind landing devices, and practi-

cally every other electronic device employing high frequencies. The electrical characteristics of the cables used in these applications must meet very rigid



specifications<sup>1</sup> and the problem of accurately measuring the characteristics is important to the cable designer to enable him to check his designs, to the cable manufacturer to inspect the cable being produced, and to the cable user to make it possible for him to determine accurately the properties of the cables with which he is working.

There has for some time been an evident need for published information on

<sup>1</sup>Joint Army-Navy Specifications, JAN-C-17A, dated July 25, 1946, "Cables, Coaxial and Twin-Conductor, for Radio Frequency."

the methods of making these measurements and the selection of the necessary equipment. We are pleased to announce that this information is now available, in the form of a paper entitled "The Measurement of Cable Characteristics," by William R. Thurston of the General Radio engineering staff.

This paper will be of interest to all manufacturers and users of coaxial, dual coaxial, and shielded twin-conductor cables. A copy will be sent free on request.

## "UNIVERSAL" COAXIAL ADAPTORS

Since the introduction of the new General Radio 874-Q Coaxial Adaptors,<sup>1</sup> it has been called to our attention that these adaptors provide the basis for a truly universal adaptor system for UG-type coaxial connectors. Interconnection between any pair of connector systems is possible with only a limited number of adaptor units.

For example, to connect a TYPE-N Jack to a TYPE-C Plug, two adaptors are needed, the TYPE 874-QNP and the

<sup>1</sup>"New Coaxial Accessories," *General Radio Experimenter*, XXVII, 5, October, 1952, pp. 1-4.

TYPE 874-QCJ. These are plugged into the respective TYPE-N and TYPE-C terminals and the TYPE 874 fittings are then plugged together.

The advantages of TYPE 874-Q Adaptors for this purpose are twofold. First, only a limited number of adaptors is needed to make any desired connection between the different UG types and, second, the joint thus formed has a very low standing-wave ratio, owing to the excellent electrical characteristics of the adaptors.

***THE General Radio EXPERIMENTER is mailed without charge each month to engineers, scientists, technicians, and others interested in communication-frequency measurement and control problems. When sending requests for subscriptions and address-change notices, please supply the following information: name, company address, type of business company is engaged in, and title or position of individual.***

### GENERAL RADIO COMPANY

275 MASSACHUSETTS AVENUE

CAMBRIDGE 39

MASSACHUSETTS

TELEPHONE: TRowbridge 6-4400

### BRANCH ENGINEERING OFFICES

NEW YORK 6, NEW YORK  
90 WEST STREET  
TEL.—WOrth 2-5837

LOS ANGELES 38, CALIFORNIA  
1000 NORTH SEWARD STREET  
TEL.—HOLlywood 9-6201

CHICAGO 5, ILLINOIS  
920 SOUTH MICHIGAN AVENUE  
TEL.—WABash 2-3820